

# TOP VIEW

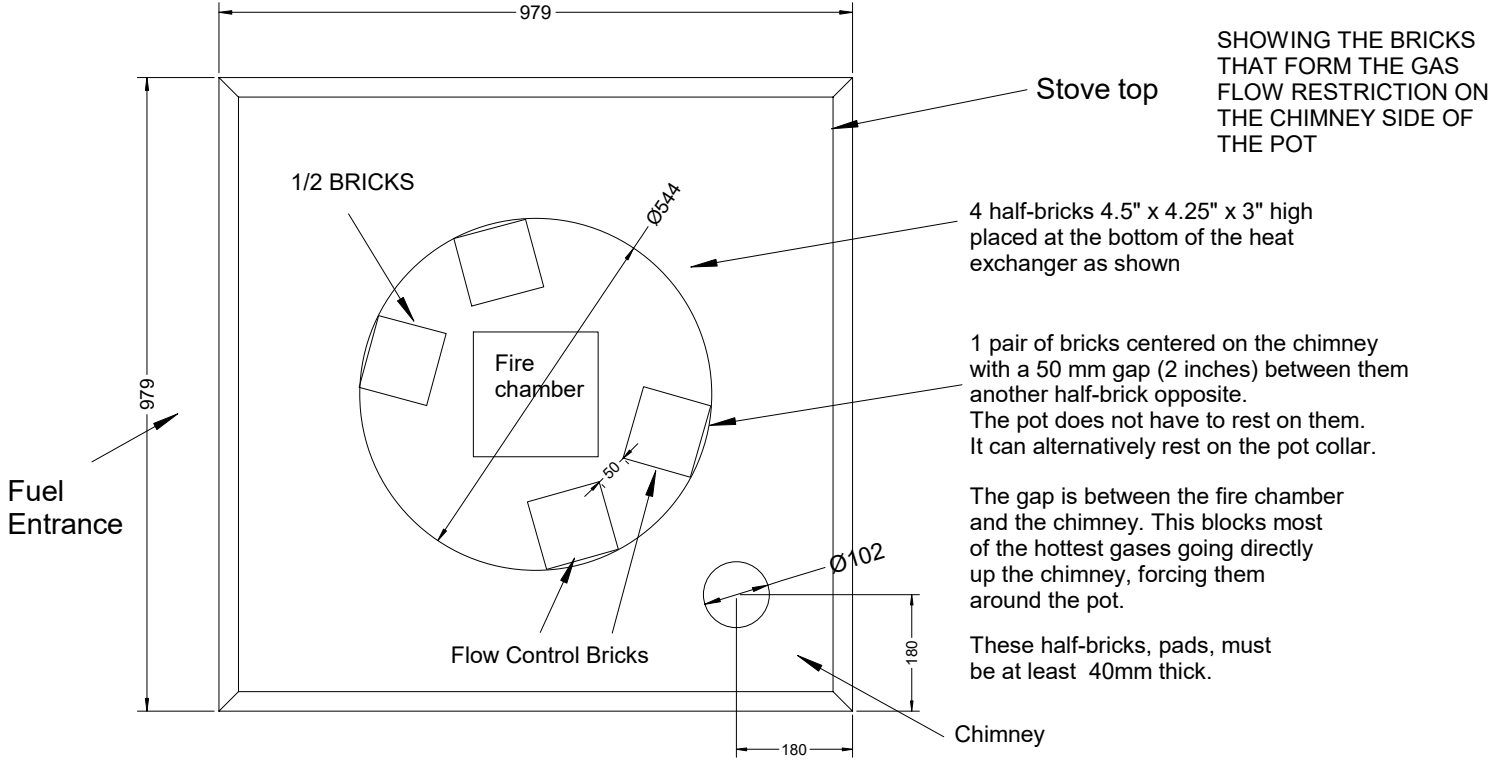

			<b>2024 MEMD 50 LITRE STOVE</b>
			<b>Key Features:</b>
			Direct exit of the gases to the chimney is partially blocked
			Chimney is in the corner
			Material: Brick and High temperature brick
			Quantity: Various
			Scale: Not to scale
Version: 1.4	Date: 2024-12-17	Initials: CPP	Drawn By: C Pemberton-Pigott
<b>Drawing No. 03 MEMD 50 Litres Top View control bricks</b>			<b>Part Top View of Blocking Bricks</b>